

SolarMount-I™ Roof Mount Technical Datasheet

Pub 100701-1td V1.0 July 2010

SolarMount-I Module Connection Hardware

- Slider and Mid Clamp..... 1
- Slider and End Clamp..... 2
- SolarMount-I Series Accessory Mount..... 2

SolarMount-I Beam Connection Hardware

- 1- Flange Foot..... 3
- 2- Flange Foot..... 3
- Beam Splice..... 4

SolarMount-I Beam

- SolarMount-I Beams..... 5

SolarMount-I Module Connection Hardware

SolarMount-I Series Slider with Mid Clamp Part No. 02027C, 02028C, 02029C, 02030C

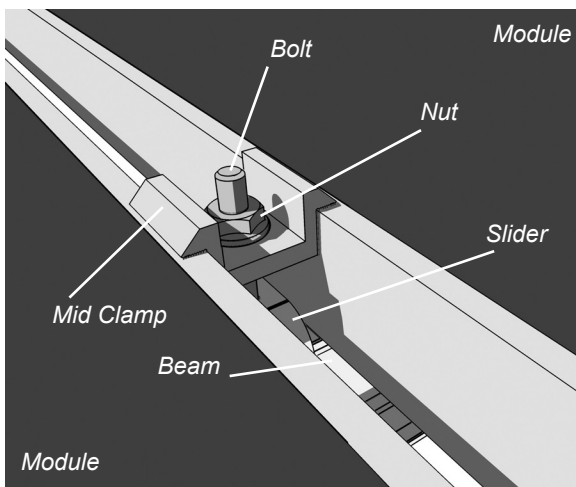

- **Slider and Mid Clamp Material:** One of the following mill finished extruded aluminum alloys: 6005-T5, 6105-T5, 6061-T6
Ultimate tensile: 38ksi, **Yield:** 35 ksi
- **Slider weight:** 0.026 lbs (12g), **Mid Clamp Weight:** 0.050 lbs (23g)
- Allowable and design loads are valid when components are assembled with SolarMount-I Beams according to authorized UNIRAC documents
- Sliders are compatible with SolarMount-I Beams
- Assemble with one ¼-20 ASTM F593 bolt and one ¼-20 ASTM F594 serrated flange nut
- Use anti-seize and tighten to 10 ft-lbs of torque
- Resistance factors and safety factors are determined according to part 1 section 9 of the 2005 Aluminum Design Manual

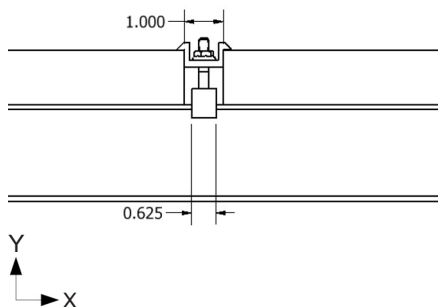

Dimensions specified in inches unless noted

Applied Load Direction	Average Ultimate lbs (N)	Allowable Load lbs (N)	Safety Factor, FS	Design Load lbs (N)	Resistance Factor, Φ
Sliding, X±	1194 (5311)	490 (2180)	2.44	741 (3296)	0.620
Tension, Y+	1503 (6686)	677 (3011)	2.22	1024 (4555)	0.682
Transverse, Z±	2080 (9252)	915 (4070)	2.27	1383 (6152)	0.665

SolarMount-I Module Connection Hardware

SolarMount-I Slider with End Clamp Part No. 02001C through 02006C, 02009C, 02010C

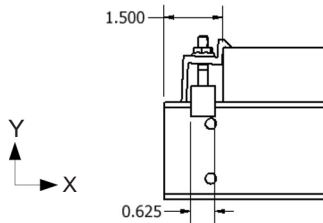
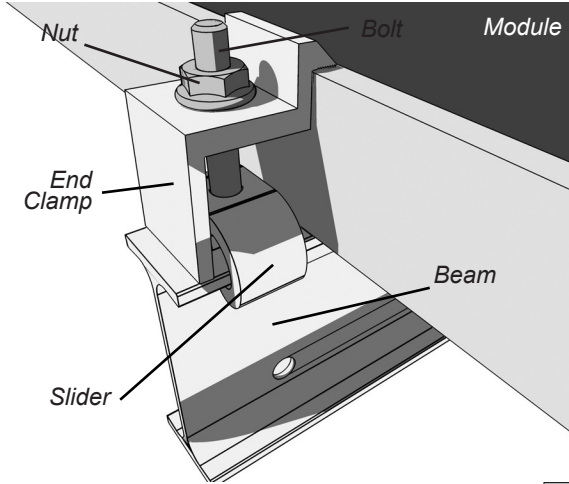

Dimensions specified in inches unless noted

- **Slider and End Clamp Material:** One of the following mill finished extruded aluminum alloys: 6005-T5, 6105-T5, 6061-T6
Ultimate tensile: 38 ksi, Yield: 35 ksi
- **Slider weight:** 0.026 lbs (12g), end clamp weight varies based on height: ~0.058 lbs (26g)
- Allowable and design loads are valid when components are assembled with SolarMount-I 1.0 or 2.5 Beams according to authorized UNIRAC documents
- Sliders are compatible with SolarMount-I Beams
- Assemble with one ¼-20 ASTM F593 bolt and one ¼-20 ASTM F594 serrated flange nut
- Use anti-seize and tighten to 10 ft-lbs of torque
- Resistance factors and safety factors are determined according to part 1 section 9 of the 2005 Aluminum Design Manual
- Modules must be installed at least 1.5" from either end of a beam

Applied Load Direction	Average Ultimate lbs (N)	Allowable Load lbs (N)	Safety Factor, FS	Design Loads lbs (N)	Resistance Factor, Φ
Sliding, X±	283 (1259)	104 (463)	2.72	157 (698)	0.555
Tension, Y+	332 (1477)	88 (391)	3.77	133 (592)	0.401
Transverse, Z±	1367 (6081)	533 (2371)	2.56	806 (3585)	0.590

SolarMount-I Accessory Mount Part No. 08010M

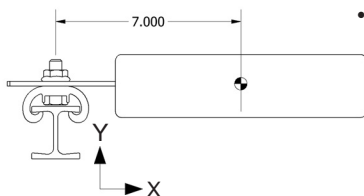
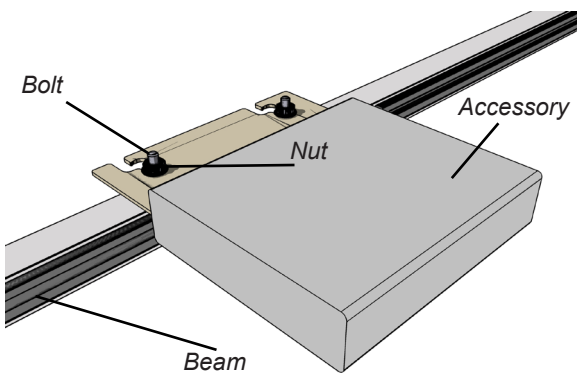

Dimensions specified in inches unless noted

- **Slider Material:** One of the following mill finished extruded aluminum alloys: 6005-T5, 6105-T5, 6061-T6
Ultimate tensile: 38 ksi, Yield: 35 ksi
- **Slider weight:** 0.026 lbs (12g)
- Allowable and design loads are valid when components are assembled with SolarMount-I 1.0 or 2.5 Beams according to authorized UNIRAC documents
- SolarMount-I Series Accessory Mounts are compatible with SolarMount-I Beams
- Use two Accessory Mounts per accessory
- **Assemble each pair of clamps with the following stainless steel hardware:** two ¼-20 set screws, two ¼-20 heavy hex jam nuts, and two ¼-20 F594 serrated flange nuts
- Use anti-seize and tighten to 5-10 ft-lbs of torque
- Resistance factors and safety factors are determined according to calculations and UNIRAC testing

Maximum distance of accessory center of gravity from beam center in (mm)	Maximum weight of accessory lbs (kg)
7 (178)	32 (14.5)

SolarMount-I Beam Connection Hardware

SolarMount-I 1- Flange Foot Part No. 04011M

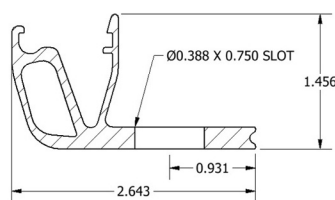
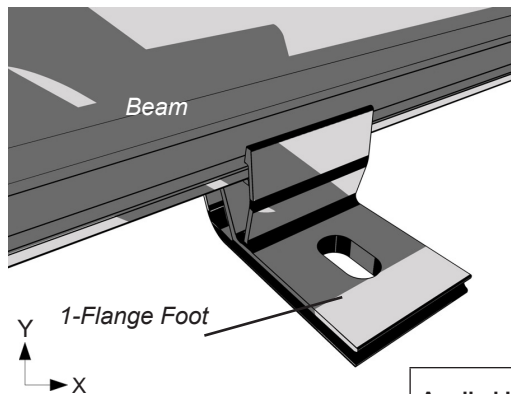

Dimensions specified in inches unless noted

- **1-Flange Foot Material:** One of the following mill finished extruded aluminum alloys: 6005-T5, 6105-T5, 6061-T6
Ultimate tensile: 38 ksi, **Yield:** 35 ksi
- **1-Flange Foot weight:** 0.101 lbs (46 g)
- Allowable and design loads are valid when components are assembled with SolarMount-I 1.0 or 2.5 Beams according to authorized UNIRAC documents
- 1-Flange feet are compatible with SolarMount-I Beams
- Resistance factors and safety factors are determined according to part 1 section 9 of the 2005 Aluminum Design Manual
- Design and allowable loads are for the beam to foot connection
- **Be sure to check load limits for roof attachments and standoffs**

Applied Load Direction	Average Ultimate lbs (N)	Allowable Load lbs (N)	Safety Factor, FS	Design Load lbs (N)	Resistance Factor, Φ
Tension, Y+					
SolarMount-I 1.0 Beam	1388 (5952)	591 (2629)	2.26	894 (3977)	0.668
SolarMount-I 2.5 Beam	1514 (6735)	648 (2882)	2.34	980 (4359)	0.647
Compression, Y-					
SolarMount-I 1.0 Beam	2931 (13038)	1288 (5729)	2.28	1948 (8665)	0.664
SolarMount-I 2.5 Beam	2750 (12233)	1223 (5440)	2.25	1849 (8225)	0.672
Transverse, X-, downhill					
	635 (2825)	313 (1392)	2.03	473 (2104)	0.745
Transverse, X+, uphill					
	42 (187)	20 (89)	2.15	30 (133)	0.705
Sliding, Z±					
	(see Beam Splice)				

SolarMount-I 2 - Flange Foot Part No. 04002M, 04003M

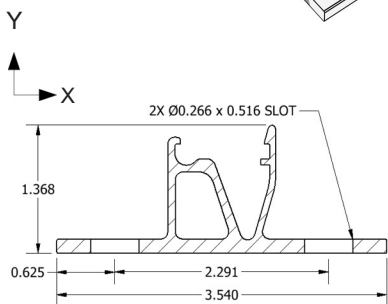
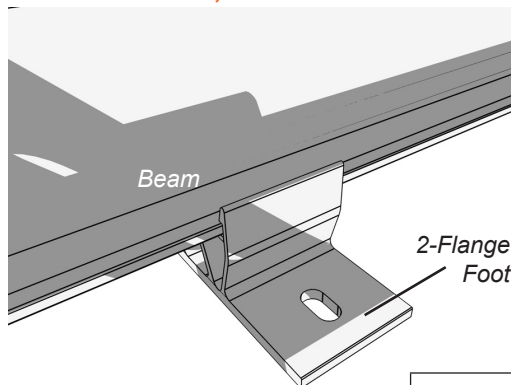

Dimensions specified in inches unless noted

- **2-Flange Foot Material:** One of the following mill finished extruded aluminum alloys: 6005-T5, 6105-T5, 6061-T6
Ultimate tensile: 38 ksi, **Yield:** 35 ksi
- **2-Flange Foot weight:** 0.103 lbs (47 g)
- Allowable and design loads are valid when components are assembled with SolarMount-I 1.0 or 2.5 Beams according to authorized UNIRAC documents
- 2-Flange Feet are compatible with SolarMount-I Beams
- Resistance factors and safety factors are determined according to part 1 section 9 of the 2005 Aluminum Design Manual
- Design and allowable loads are for the beam to foot connection
- **Be sure to check load limits for roof attachments and standoffs**

Applied Load Direction	Average Ultimate lbs (N)	Allowable Load lbs (N)	Safety Factor, FS	Design Load lbs (N)	Resistance Factor, Φ
Tension, Y+					
SolarMount-I 1.0 Beam	1931 (8950)	864 (3843)	2.23	1307 (5814)	0.667
SolarMount-I 2.5 Beam	2478 (11023)	1111 (4942)	2.23	1681 (7477)	0.678
Compression, Y-					
SolarMount-I 1.0 Beam	3788 (16850)	1706 (7589)	2.22	2581 (11481)	0.681
SolarMount-I 2.5 Beam	3694 (16432)	1562 (6948)	2.36	2363 (10511)	0.640
Transverse, X-, downhill					
	635 (2825)	313 (1392)	2.03	473 (2104)	0.745
Transverse, X+, uphill					
	42 (187)	20 (89)	2.15	30 (133)	0.705
Sliding, Z±					
	(see Beam Splice)				

SolarMount-I Beam Connection Hardware

SolarMount-I Beam Splice Part No. 03020M, 03021M

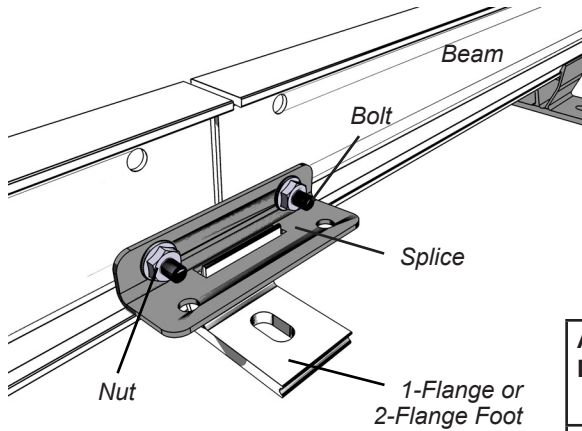

- **Beam Splice Material:** Aluminum 5052-H32
Ultimate tensile: 31 ksi, Yield: 23 ksi
- **Beam Splice weight:** 0.053 lbs (24 g)
- Allowable and design loads are valid when components are assembled according to authorized UNIRAC documents
- Beam Splices are compatible with SolarMount-I Beams when used with 1-Flange or 2-Flange feet
- Resistance factors and safety factors are determined according to part 1 section 9 of the 2005 Aluminum Design Manual

Applied Load Direction	Average Ultimate lbs (N)	Allowable Load lbs (N)	Safety Factor, FS	Design Load lbs (N)	Resistance Factor, Φ
Sliding, \pm	1428 (6352)	620 (2758)	2.30	938 (4172)	0.657

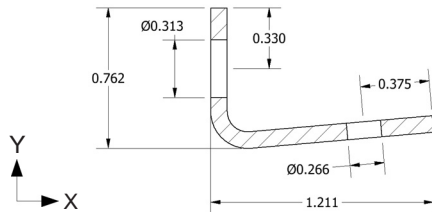

Dimensions specified in inches unless noted

SolarMount-I Beam

MATERIAL: One of the following extruded aluminum alloys: 6005-T5, 6105-T5, or 6061-T6, Mill Finish			
Properties	Units	Beam Height (in)	
		1.094	2.500
Approximate Weight (per linear ft)	plf	0.356	0.548
Total Cross Sectional Area	in ²	0.3037	0.4665
Section Modulus (X-Axis)	in ³	0.1101	0.3687
Section Modulus (Y-Axis)	in ³	0.0390	0.0422
Moment of Inertia (X-Axis)	in ⁴	0.0602	0.4609
Moment of Inertia (Y-Axis)	in ⁴	0.0195	0.0211
Radius of Gyration (X-Axis)	in	0.4453	0.9940
Radius of Gyration (Y-Axis)	in	0.2536	0.2127

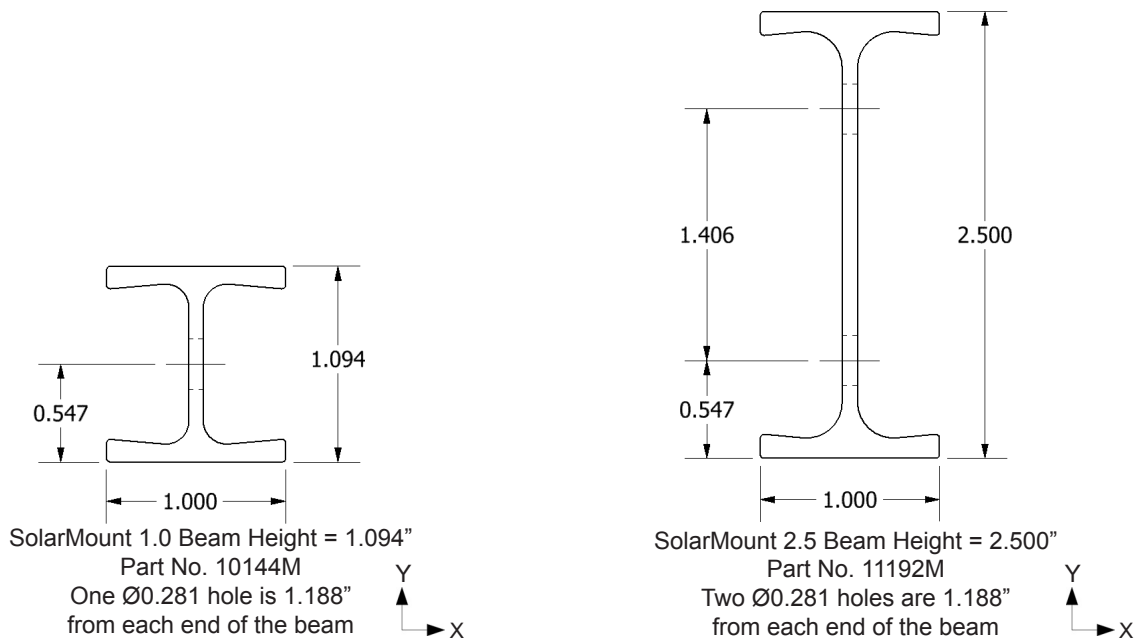

Dimensions specified in inches unless noted